

LIGHTLIFT 20.10

PERFORMANCE III S MK2

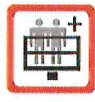

20,15 m



9,70 m



5,01 m



4,66 m

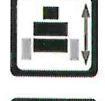

1,99 m

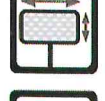

1335x690xh.1100 mm



124° (+/-62°)



16°/28,7%



2840 kg / 6261 lb (Honda)
2940 kg / 6481 lb (Perkins)
2950 kg / 6503 lb (lithium-ion)



Honda IGX440 Automatic rpm control 12,7 CV - 3600rpm
Perkins 402.05 14CV - 3600 rpm



2,2kw-230V-50Hz
2,2kw-110V-50Hz



0,5-1,3-2,5 Km/h



795 - 1095 mm



2150 daN - 3,04 daN/cm²

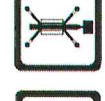

2922x2925 mm



Automatic set up system III S std
III S - Abstütz- und Einfahrautomatik serienmässig



Remote control
Kabelfernbedienung

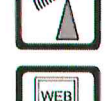

GPRS-GPS



R.A.H.M.



100Ah/72V
Optional - Optional

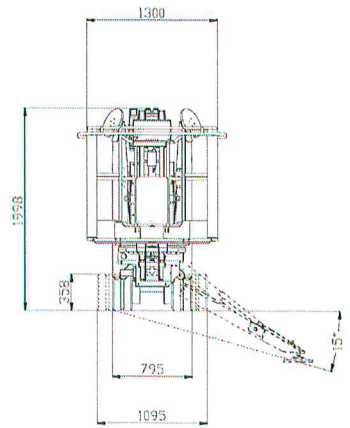
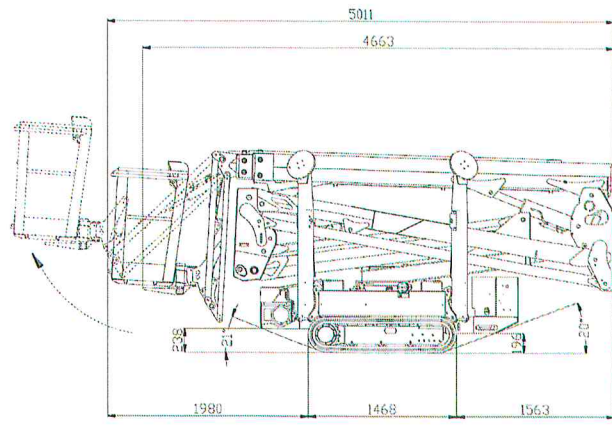

LIGHTLIFT 20.10 PERFORMANCE III S MK2

Reichweitendiagramm

